

INSTALLATION & USER INSTRUCTIONS

WALL MOUNTED ELECTRIC FIRE



Focal Point Fires plc.
Christchurch, Dorset BH23 2BT
Tel: 01202 499330
Fax: 01202 499326
www.focalpointfires.co.uk
Email: sales@focalpointfires.co.uk

MODELS COVERED BY THESE INSTRUCTIONS

Charmouth
Osmington
Yeovilton
Shaftesbury
EF11-35

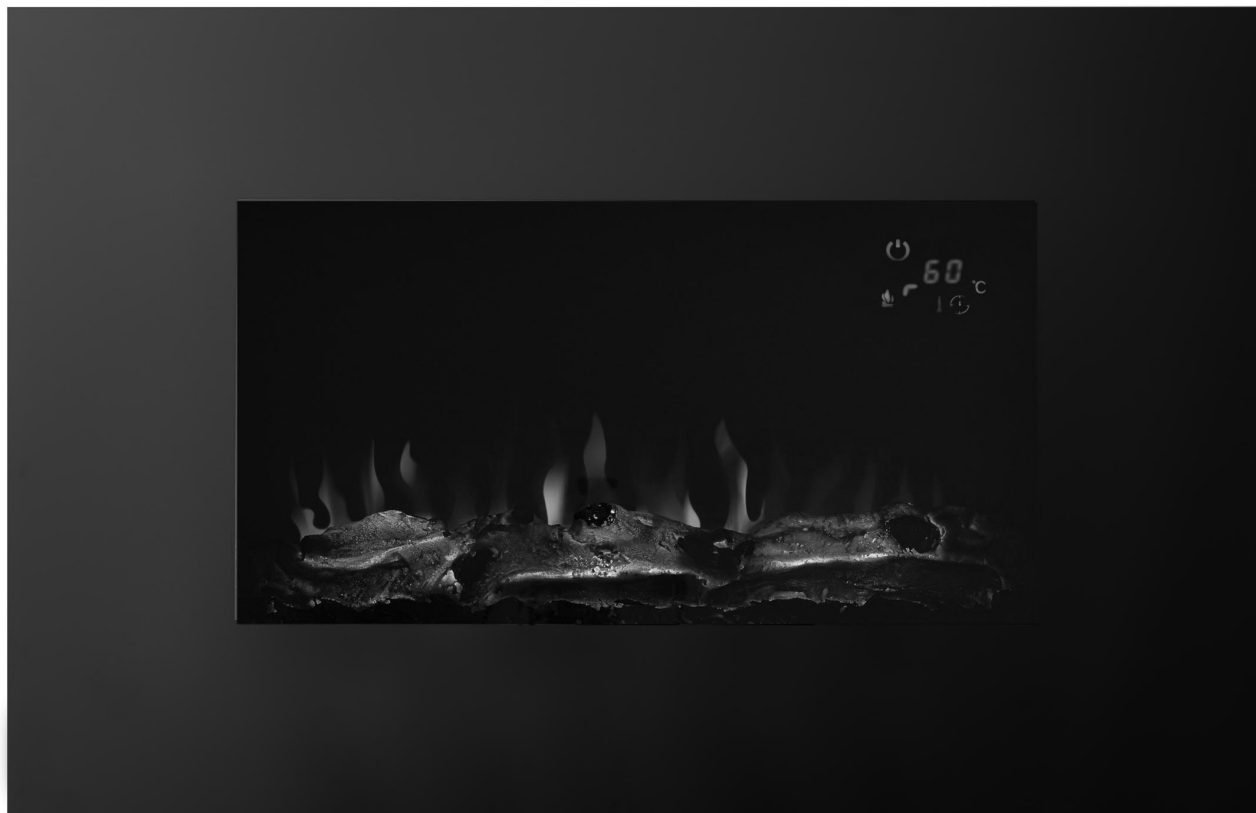

Model shown: Charmouth

Questions or problems with your appliance?

Don't take it back to the store

just give us a call on **01202 588601** we're here to help
lines open between 9am and 5pm, Monday to Friday

3 YEAR GUARANTEE

SUBJECT TO TERMS & CONDITIONS

For details please see: www.focalpointfires.co.uk/tandcs or telephone
01202 588635 Option 7

Please note: Except where otherwise stated, all rights, including copyright in the text, images and layout of this booklet is owned by Focal Point Fires plc. You are not permitted to copy or adapt any of the content without the prior written permission of Focal Point Fires plc.

All instructions must be handed to the user for safekeeping.

Revision L - 08/15

| Section | Contents | Page No. | Section | Contents | Page No. |
|---------|----------------------------|----------|---------|----------------------------------|----------|
| 1.0 | Important Notes | 2 | 8.0 | Installing the Appliance | 4 |
| 2.0 | Installation Requirements | 3 | 9.0 | Operating the Appliance | 5 |
| 3.0 | Appliance Data | 3 | 10.0 | Safety Cutout System | 6 |
| 4.0 | Unpacking the Appliance | 3 | 11.0 | Cleaning and Maintenance | 6 |
| 5.0 | Component Checklist | 3 | 12.0 | Spares | 6 |
| 6.0 | Site Requirements | 3 | 13.0 | Servicing | 6 |
| 7.0 | Clearances to Combustibles | 4 | 14.0 | Troubleshooting Guide | 7 |
| | | | 15.0 | Guarantee - Terms and Conditions | 7 |

1.0 IMPORTANT NOTES

IMPORTANT - THESE INSTRUCTIONS SHOULD BE READ CAREFULLY AND RETAINED FOR FUTURE REFERENCE.

When using this electrical appliance, basic precautions should be followed to reduce the risk of fire, electric shock and injury to person, including the following:

- This heater must be used on an AC supply only and the voltage marked on the heater's rating label must correspond to the supply voltage.
- **DO NOT** switch the appliance on until it is properly installed as described in this manual.
- This appliance can be used by children aged from 8 years and above and persons with reduced physical, sensory or mental capabilities or lack of experience and knowledge if they have been given supervision or instruction concerning use of the appliance in a safe way and understand the hazards involved. Children shall not play with the appliance. Cleaning and user maintenance shall not be made by children without supervision.
- Children of less than 3 years should be kept away unless continuously supervised. Children aged from 3 years and less than 8 years shall only switch on/off the appliance provided that it has been placed or installed in its intended normal operating position and they have been given supervision or instruction concerning use of the appliance in a safe way and understand the hazards involved. Children aged from 3 years and less than 8 years shall not plug in, regulate and clean the appliance or perform user maintenance.
- **CAUTION:** Some parts of this product can become very hot and cause burns. Particular attention has to be given where children and vulnerable people are present.
- If the supply cord is damaged, it must be replaced by the manufacturer, its service agent or similarly qualified persons in order to avoid a hazard.
- The heater must not be located immediately above a socket-outlet.
- **DO NOT** use this heater in the immediate surroundings of a bath, a shower or a swimming pool.



- **WARNING:** In order to avoid overheating, do not cover the heater.
- **DO NOT** use this heater with a programmer, timer, separate remote-control system or any other device that switches the heater on automatically, since a fire risk exists if the heater is covered or positioned incorrectly.
- **CAUTION:** In order to avoid a hazard due to inadvertent resetting of the thermal cutout, this appliance must not be supplied through an external switching device, such as a timer, or connected to a circuit that is regularly switched on and off by the utility.
- Keep furniture, curtains and other fabric material away from the appliance.
- **DO NOT** leave the appliance unattended during use.
- From time to time, check the cord for damage. Never use the appliance if the cord or any part of the appliance shows signs of damage.

- **DO NOT** run the mains cable under carpets, rugs etc.
- **DO NOT** cover or obstruct the heater in any way. Overheating will result if it is accidentally covered.
- Never immerse the product in water or any other liquids.
- **DO NOT** use the appliance outdoors.
- Before cleaning the appliance, ensure it is unplugged from the power and that it is completely cool.
- **DO NOT** clean the appliance with abrasive chemicals.
- Never use accessories that are not recommended or supplied by the manufacturer. It could cause danger to the user or damage to the appliance.
- **DO NOT** insert or allow foreign objects to enter the inlet or outlet vents as this may result in electric shock, fire or damage to the appliance.
- **DO NOT** install the fire using an extension cord.
- Unplug from the mains supply if the appliance is not to be used for long periods.

2.0 INSTALLATION REQUIREMENTS

The appliance is supplied with a pre-wired three pin plug (13 Amp fuse rated) and 1.8 metres of electrical cable. It is therefore necessary for a suitable electrical socket to be located within this distance and be easily accessible. This appliance is designed to be wall hung, using the wall fixtures/fixings provided. DO NOT recess any part of appliance into the wall. This appliance is suitable for installation in static holiday/park homes.

3.0 APPLIANCE DATA

| | | | |
|--|-------------------------|---------------------------|--------------------------|
| Supply Voltage and rating power : | 220-240V AC 50Hz, 1800W | Fuse Rating: | 13 Amp |
| Heating Elements: | 1800W | Lighting: | LED |
| Location : | Indoor use only | Supply plug/cord : | BS1363/1.8 metres length |

This fire is fitted with LED's (Light Emitting Diode) in place of conventional bulbs. LED's generate the same light levels as conventional bulbs, but use a fraction of the energy consumed. LED's are maintenance free and will not require replacing during the life of the product.

4.0 UNPACKING THE APPLIANCE

Read **all** the instructions before continuing to unpack or install this appliance. Carefully remove the appliance from its packaging and lay on the floor with it's back surface downward. Note: DO NOT stand the appliance on its frame as this may cause distortion. Check that the remaining packaging contents correlate with the component checklist below. Please dispose of all packaging at your local recycling centre.

5.0 COMPONENT CHECKLIST

QUANTITY DESCRIPTION

| | |
|--|---|
| | Wall heater |
| | Decorative fascia |
| | Rear fascia (selected models only) |
| | Instruction booklet |
| | Remote control |
| | Pack of fixing screws and wall plugs (5 x 30mm pozi pan head screws / 5 x wall plugs) |
| | Wall mounting bracket |

6.0 REQUIREMENTS

This appliance is designed to be wall mounted using the mounting bracket and fixings provided. The wall should be relatively flat and not interfere with any of the ventilation slots in the rear panel.

The wall must be structurally sound and of a material capable of withstanding moderate heat. Finished plaster, conventional wallpaper, dry-lined plaster board are examples of suitable materials. Materials such as flock, blown vinyl, embossed paper and cloth wall coverings which are sensitive to even small amounts of heat should be avoided, as some discolouration may occur. It should be noted that the appliance creates warm convected air currents. These currents move heat from the room surroundings to, and up the wall surfaces adjacent to the heater.

Installing the heater next to these types of wall coverings or operating the heater where impurities in the air, (such as tobacco smoke) exist, may slightly discolour wall finishing.

If the appliance is to be mounted on a dry lined or timber framed construction then the integrity and ability of the wall to

carry the weight of the appliance must be confirmed. It is important in these circumstances that any vapour barrier and/or structural members of the house frame are not damaged.

If you are unsure of the ability of the wall to carry the weight and/or which type of wall fixing to use, you should take professional advice and obtain the correct fixings. Alternatively, find a more suitable wall location.

DO NOT

- mount on a ceiling or floor
- recess any part of the appliance into the wall, or run the supply cable under carpets
- site any electrical equipment e.g. plasma screen TV sets etc, on the wall below the appliance
- site in a position where curtains or drapes could cover the appliance, or other soft materials could cover e.g. below a coat rack
- site behind an opening door where mechanical impact/damage could occur
- site where the supply cable would become a trip hazard
- sit, stand or forcefully pull on the appliance
- obstruct, cover or force items into the openings
- use the heater to dry clothes
- site/use in an outdoor location(s)

7.0 CLEARANCES TO COMBUSTIBLE MATERIALS

It is important that the following clearances are maintained from the appliance to combustible materials. These clearances are dependent on the mounting location as defined below:

- The minimum distance from the top of the appliance to a ceiling is 300mm
- The minimum distance from the bottom of the appliance to the floor is 300mm
- The minimum distance to the sides of the appliance is 100mm
- The minimum distance to the front of the appliance is 500mm

8.0 INSTALLING THE APPLIANCE

CAUTION: DO NOT CONNECT THE APPLIANCE TO THE ELECTRICAL SUPPLY AT THIS TIME.

Focal Point Fires plc. assumes absolutely no responsibility for injuries and damages that may occur due to improper installation or handling.

Remove any protective film coatings from the finished/decorative surfaces of the appliance, if any. After having selected the final mounting position of the appliance taking into account the integrity of the wall the firebox of the appliance may be secured to the wall.

To ensure customer safety, be sure to design the installation so that the strength of both the wall and any wall fixings used are sufficient. The appliance should not be installed until all wet plastering and/or dry wall sanding and wall painting has been completed. Do not block the ventilation holes of the appliance. The wall onto which the appliance is installed must be flat. Install only on a vertical surface. Avoid sloped surfaces. Installation onto anything other than a vertical wall may result in fire, damage or injury.

If the appliance is to be mounted on the inner leaf of a conventional cavity brick wall, or a solid wall, then the wall plugs and fixing screws provided may be used. Depending on the condition of the wall it may be necessary to use additional fixings. In this situation, any additional fixings and wallplugs should be of the same size and type as the ones provided.

If the appliance is to be mounted on a dry lined wall or a timber framed construction wall then efforts should be made to fix in at least two positions vertically, into one of the wooden studs, or supporting wooden members of the wall using two of the fixing screws provided. If this is not achievable then the wall should be strengthened using appropriate building materials.

If there is no alternative than to rely on some plasterboard fixings then special cavity screw fixings or hollow wall anchors will be required which are not supplied with this product. These should be constructed from metal and not plastic and of the design indicated (Figure 1). For further guidance for wall fixing in timber framed buildings refer to any relevant local codes of practice.

For optimum viewing install the fire out of direct sunlight. Ensure that the bracket is level by using a spirit level whilst marking out the hole positions. Fix the wall bracket using the plugs and screws provided. Carefully lift the heater up ensuring

WARNING

The wall where the appliance is to be installed must be capable of long-term support of the total load of the appliance. Measures should also be taken to ensure sufficient strength to withstand the force of earthquakes, vibration and other external forces. Plasterboard alone is not considered to be a structural material. It is not recommended to rely on plasterboard fixings alone to support the weight of the appliance.

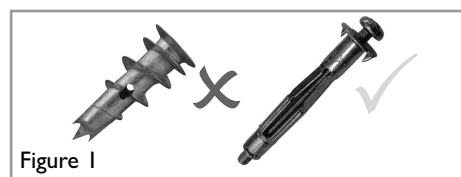

Figure 1

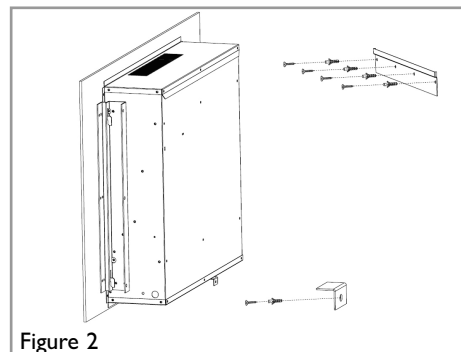

Figure 2

8.0 INSTALLING THE APPLIANCE - CONTINUED

GB IE

that the top rear ledge of heater engages with the wall bracket and is sitting centrally. This process should be carried out by two people to avoid injury or damage to property or the appliance.

Gently bring the heater down against the wall. Mark the lower fixing bracket one fixing hole position on the wall, remove the heater. Drill the wall and insert the wall plug. Refit the heater to the wall and fasten the bottom fixing bracket to the wall using the screw provided to permanently fix the heater in place (Figure 2).

Place the front surround over the front of the fire aligning the slots in the brackets at each side of the front panel with the lugs on the sides of the fire (Figure 3). Again two people will be required for this operation.

Check that the fan outlet, mounted underneath the appliance, is not covered or obstructed in any way. Ensure the power to the fire is switched ON.

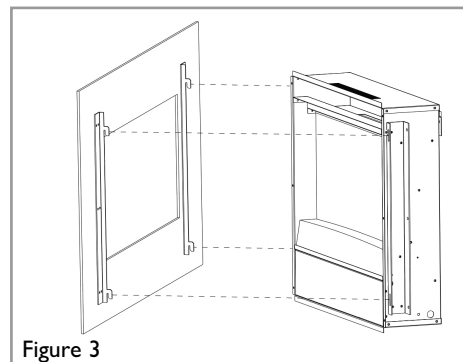





Figure 3

9.0 OPERATING THE APPLIANCE - READ BEFORE USE

The control panel is located underneath the decorative frame on the bottom right hand side of the appliance.

CONTROL PANEL







-  **MAINS POWER ON/OFF**
-  **FLAME BRIGHTNESS (5 settings)**
Press to adjust the brightness level
FULL (5) - HIGH (4) - MEDIUM (3) - LOW (2) - DIM (1) - (LOOP)
-  **HEATING (7 settings)**
Press \wedge / \vee to adjust the temperature level
60°C/99°F - 30°C/86°F - 28°C/82°F - 26°C/78°F - 24°C/75°F - 22°C/71°F - OFF - (LOOP) Press button for 10s to convert between °C and °F (model dependent)
-  **EMBER/FUELBED EFFECT**
Press to select the dynamic fuelbed effect

All of the appliances features can be operated by the remote control.

Check that the fan outlet, mounted underneath the appliance, is not covered or obstructed in any way. Ensure the power to the fire is switched ON.

REMOTE CONTROL



-  **STANDBY - ON/OFF**
OFF will cancel the OFF TIMER and the flame brightness slowly fades to OFF.
-  **FLAME BRIGHTNESS (5 settings)**
Press \wedge / \vee to adjust the brightness level
FULL (5) - HIGH (4) - MEDIUM (3) - LOW (2) - DIM (1)
-  **HEATING (7 settings)**
Press \wedge / \vee to adjust the temperature level
60°C/99°F - 30°C/86°F - 28°C/82°F - 26°C/78°F - 24°C/75°F - 22°C/71°F - OFF - (LOOP)
-  **OFF TIMER**
Press to set the OFF TIMER
10m - 20m - 30m - 40m - 50m - 1H - 2H - 3H - 4H - 5H - 6H - 7H - 8H - 9H - (LOOP)
-  **EMBER/FUELBED EFFECT**
Press to select the dynamic fuelbed effect

10.0 SAFETY CUTOUT SYSTEM

GB IE

This product has one non-self-resetting overheat protection device (thermal cut-out) which will activate if the air inlets or outlets are obstructed. For safety reasons the fire will NOT switch on again automatically, the following procedure must be carried out before the fire can be operated.

NOTE: The visual effect will remain operational if the cutout is activated, only the fan heater is prevented from working.

Switch OFF the appliance **at the wall socket or outlet**. Leave the fire OFF for a period of no less than 10 minutes, ensuring all obstructions are removed. Switch the appliance ON **at the wall**. Ensure the appliance is turned ON at the control switches. If the fire fails to operate correctly, repeat the above procedure. If an attempt to switch on the appliance is made before the safety cutout has reset, the appliance may cutout for a further period of time. If the sequence has been followed correctly and the appliance still fails to function, check the fuse in the wall outlet. If this is not the cause, call an electrician or maintenance engineer.

11.0 CLEANING AND MAINTENANCE

ALWAYS DISCONNECT THE APPLIANCE FROM THE MAINS SUPPLY OUTLET SOCKET BEFORE UNDERTAKING ANY CLEANING OR MAINTENANCE!

For general cleaning use a soft clean duster - never use harsh abrasive or cleaners. The glass viewing screen should be cleaned carefully with a soft cloth.

If in doubt consult a qualified electrician. Refer to Section 3.0 Appliance Data for fuse specification. Excluding fuses, use only genuine manufacturers spare parts available from your supplier.

Replacing the remote control battery:

When the battery becomes weak, the range of the remote control becomes shorter. Replace the battery with a new CR2025 lithium battery.

Note: Keep the lithium battery out of the reach of children.

12.0 SPARES

Refer to Section 3.0 Appliance Data for lamp and fuse specification. Excluding lamps and fuses, use only genuine manufacturers spare parts available from your supplier.

13.0 SERVICING

There are no internal user serviceable parts.

Check regularly for security of wall fixings as appropriate. Also check security of supply cable and connections. If the supply cable becomes damaged, it must be replaced by a service agent or competent person, such as a qualified electrician.

This appliance is supplied with a BS1363 3 pin plug fitted with a 13 Amp fuse. Should the fuse require replacing, it must be replaced with a fuse rated at 13 Amp and approved to BS1362. In the event of the mains plug being removed/replaced for any reason, please note : **IMPORTANT:** The wires in the mains lead are coloured in accordance with the following code:

Blue - Neutral

Brown - Live

Green/ Yellow - Earth

As the colours of the wires in the mains lead of this appliance may not correspond with the colour markings identifying the terminals in your plug, proceed as follows.

The blue wire must be connected to the terminal marked with an N or

coloured black. The brown wire must be connected to the terminal marked with an L or coloured red. The green/yellow wire must be connected to the earth terminal which is marked with an E or with the earth symbol. **WARNING:** Never connect live or neutral wires to the earth terminal of the plug.

NOTE: If a moulded plug is fitted and has to be removed take great care in disposing of the plug and severed cable, it must be destroyed to prevent engaging into a socket.

Refer to Section 3.0, Appliance Data for fuse specification. Excluding fuses, use only genuine manufacturers spare parts available from your supplier.

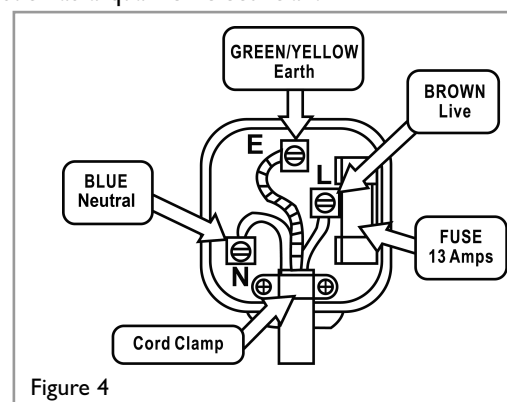

14.0 TROUBLESHOOTING GUIDE

GB IE

| | |
|--|--|
| Fire is not switching on | Ensure mains switch is on Replace the fuse in the plug |
| Fire is not emitting any heat | The fire is fitted with an energy saving thermostat. If the temperature in the room is higher than the temperature selected on the fire, then the thermostat will stop the heater from turning on. For example, if the room temperature is 22°C or above and the fire's heater is set at 22°C, then the heater will not be required until the room temperature drops below 22°C. If this is the case select a higher temperature setting than the room's temperature and the heater will begin to operate. The safety cut-out may have operated. Switch your fire off, leave for two minutes and then switch back on. |
| Fire shuts off after a period of time | Check that the temperature is not set onto the lower settings. If the room is warm enough the thermostat will stop the fire switching the heat on. Check that the chimney/flue is blocked off. |
| Fire seems noisy | There is a level of noise when the flame effect is in use, caused by a motor that helps generate the effect. This noise will be heard when there is no other background noise. There is a higher level of noise associated with the heater motor; this is due to the air flow required when heat has been selected. |
| Remote is not operating | Check or replace batteries. |

15.0 GUARANTEE - TERMS AND CONDITIONS

The 3 year guarantee only covers products purchased on or after 1st February 2009. For all gas fires purchased the 3 year guarantee commences from the date of purchase, provided that the following 3 terms and conditions are adhered to:

Registration is not required.

1. For any claim to be made within the 3 years from date of purchase you will be required to provide and supply us with your proof of purchase.
2. Your gas fire must have been commissioned by a CORGI/Gas Safe* registered installer, evidence of which you must provide together with the CORGI/Gas Safe* registration number.
3. Your appliance must have been serviced annually, irrespective of use, by a CORGI/Gas Safe* registered installer, evidence of which must be provided, such as the receipt.

Please note all consumable items such as any ceramics including; coals, pebbles, the matrix, front strips, side cheeks, rear panels and tapered rear panels are not covered by the 3 year guarantee. For all Electric fires purchased the 3 year guarantee commences from the date of purchase, providing that you can supply the proof of purchase. This does not cover consumable items such as pebbles, coals or light bulbs.

Making a claim is easy.

If you wish to make a claim under our 3 year guarantee and all the terms and conditions for your product have been met then please submit the following information for the attention of the 3G Service Department to the address below. Alternatively, you can email or fax. Please note that this does not affect your statutory rights.

Focal Point Fires plc, 3G Service Department, Reid Street, Christchurch, Dorset, BH23 2BT.
Alternatively email: 3g@focalpointfires.co.uk or fax. 01202 499326.

Details required:

1. Name, full address including post code and contact telephone number.
2. Receipt of purchase or credit card statement.
3. Original installers CORGI/Gas Safe* registration number (gas fires only).
4. Annual service receipt for every 12 months (gas fires only).

*Gas Safe Register replaced CORGI as the gas registration body in Great Britain and the Isle of Man on 1st April 2009.



Waste electrical products should not be disposed of with household waste. Please recycle where facilities exist. Check with your local authority or retailer for recycling advice.

As our policy is one of continuous improvement and development, we therefore hope that you will understand we must retain the right to amend details and/or specifications without prior notice.